



## Sospensioni Integrative per veicoli industriali Integrative Suspensions for industrial vehicles



Top Drive System Ref. :

	Gonfiaggio <i>Inflating</i>
<b>E</b>	Elettrico <i>Electric</i>

**583064E**

Midliner 170 - 180 - 200 - 230 - 250  
Midlum 300

Fino ad esaurimento scorte / *Until stock last*

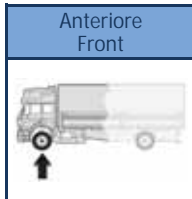

Data / Date		Dettagli veicolo / Vehicle's detail	
Da / Since :			
Fino a / Until:			
Tipo assale / Axle type		Larghezza balestra / Leaf spring width	
<b>I</b>			75 - 80 - 90



Top Drive System Ref. :

	Gonfiaggio <i>Inflating</i>
<b>A</b>	Autolivellante <i>Self-levelling</i>
<b>E</b>	Elettrico <i>Electric</i>

**583049A**

**583049E**

Midlum

180 250 280

Fino ad esaurimento scorte / *Until stock last*

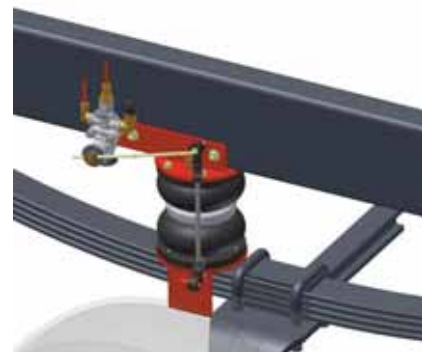
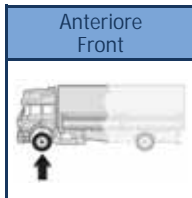

Data / Date		Dettagli veicolo / Vehicle's detail	
Da / Since :			
Fino a / Until:			
Tipo assale / Axle type		Larghezza balestra / Leaf spring width	
<b>I</b>			80



Top Drive System Ref. :

	Gonfiaggio <i>Inflating</i>
<b>A</b>	Autolivellante <i>Self-levelling</i>
<b>E</b>	Elettrico <i>Electric</i>
<b>T</b>	Elettrico con Telecomando <i>Remote controlled</i>

**583548A**

**583548E**

**583548ET**

Midlum

150 ÷ 180 DCI Common Rail

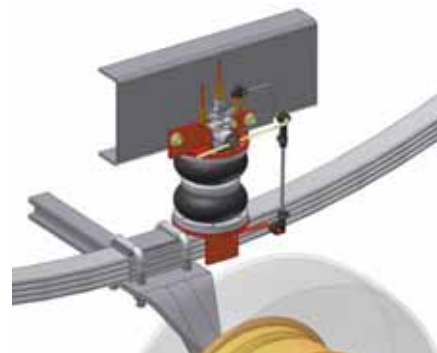
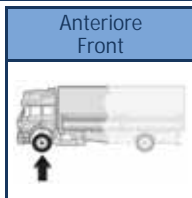

Data / Date		Dettagli veicolo / Vehicle's detail	
Da / Since :			Motore : 4 cil. <i>Engine : 4 cil.</i>
Fino a / Until:			
Tipo assale / Axle type		Larghezza balestra / Leaf spring width	
<b>I</b>			70





## Sospensioni Integrative per veicoli industriali Integrative Suspensions for industrial vehicles



Top Drive System Ref. :		Gonfiaggio <i>Inflating</i>	Anteriore Front
<b>583531A</b>	A	Autolivellante <i>Self-levelling</i>	
<b>583531E</b>	E	Elettrico <i>Electric</i>	
<b>583531ET</b>	T	Elettrico con Telecomando <i>Remote controlled</i>	
<b>Midlum</b> 150 DCI Common Rail			Torpress 281 Ø8"
			550043 - 550033
Data / Date		Dettagli veicolo / Vehicle's detail	
Da / Since :	06/2002	Motore : 6 cil. <i>Engine : 6 cil.</i>	
Fino a / Until:			
Tipo assale / Axle type		Larghezza balestra / Leaf spring width	
<b>I</b>		70	



Top Drive System Ref. :		Gonfiaggio <i>Inflating</i>	Anteriore Front
<b>583549A</b>	A	Autolivellante <i>Self-levelling</i>	
<b>583549E</b>	E	Elettrico <i>Electric</i>	
<b>583549ET</b>	T	Elettrico con Telecomando <i>Remote controlled</i>	
<b>Midlum</b> 180 ÷ 280 DCI Common Rail No Dxi			Torpress 281 Ø8"
			550043 - 550033
Data / Date		Dettagli veicolo / Vehicle's detail	
Da / Since :			
Fino a / Until:			
Tipo assale / Axle type		Larghezza balestra / Leaf spring width	
<b>I</b>		80	



Top Drive System Ref. :		Gonfiaggio <i>Inflating</i>	Anteriore Front
<b>583111A</b>	A	Autolivellante <i>Self-levelling</i>	
<b>583111E</b>	E	Elettrico <i>Electric</i>	
<b>583111ET</b>	T	Elettrico con Telecomando <i>Remote controlled</i>	
<b>Midlum</b> 160 ÷ 220 Dxi 5 (Euro 5)			Torpress 281 Ø8"
			550043 - 550033
Data / Date		Dettagli veicolo / Vehicle's detail	
Da / Since :	11/2006	Motore : 4 cil <i>Engine : 4 cil.</i>	
Fino a / Until:			
Tipo assale / Axle type		Larghezza balestra / Leaf spring width	
<b>I</b>		70	





## Sospensioni Integrative per veicoli industriali Integrative Suspensions for industrial vehicles



Top Drive System Ref. :

	Gonfiaggio <i>Inflating</i>
E	Elettrico <i>Electric</i>
T	Elettrico con Telecomando <i>Remote controlled</i>

**583911E**

**583911ET**

**Midlum**

**Versione rinforzata / Reinforced version**

160 ÷ 220 Dxi 5 (Euro 5)

Anteriore  
Front

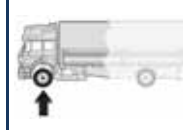

Torpress 20

Ø10"



550044 - 550034



Data / Date		Dettagli veicolo / Vehicle's detail	
Da / Since :	11/2006		Motore : 4 cil <i>Engine : 4 cil.</i>
Fino a / Until:			
Tipo assale / Axle type		Larghezza balestra / Leaf spring width	
<b>I</b>			70



Corredato di  
*Equipped with*



**TOP DRIVE  
CONTROL**

Top Drive System Ref. :

	Gonfiaggio <i>Inflating</i>
E	Elettrico <i>Electric</i>
T	Elettrico con Telecomando <i>Remote controlled</i>

**583569E**

**583569ET**

**Midlum**

240 ÷ 280 Dxi 7

Anteriore  
Front

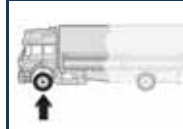

Torpress 20

Ø10"



550044 - 550034



Data / Date		Dettagli veicolo / Vehicle's detail	
Da / Since :	11/2006		
Fino a / Until:			
Tipo assale / Axle type		Larghezza balestra / Leaf spring width	
<b>I</b>			80



Corredato di  
*Equipped with*



**TOP DRIVE  
CONTROL**

Top Drive System Ref. :

	Gonfiaggio <i>Inflating</i>
E	Elettrico <i>Electric</i>
T	Elettrico con Telecomando <i>Remote controlled</i>

**583547E**

**583547ET**

**Premium**

320 ÷ 420 DCI Common Rail

Anteriore  
Front



Torpress 20

Ø10"



550044 - 550034

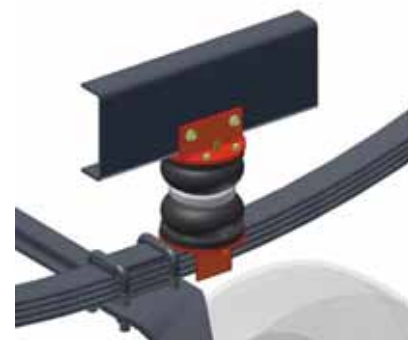

Data / Date		Dettagli veicolo / Vehicle's detail	
Da / Since :			
Fino a / Until:			
Tipo assale / Axle type		Larghezza balestra / Leaf spring width	
<b>I</b>			90



Corredato di  
*Equipped with*





**TOP DRIVE  
CONTROL**







## Sospensioni Integrative per veicoli industriali Integrative Suspensions for industrial vehicles



Top Drive System Ref. :  **583566A**  
**583566E**  
**583566ET** 

<b>A</b>	Gonfiaggio <i>Inflating</i>	Anteriore Front
<b>E</b>	Autolivellante <i>Self-levelling</i>	
<b>T</b>	Elettrico <i>Electric</i>	Torpress 20 Ø10"
	Elettrico con Telecomando <i>Remote controlled</i>	
550044 - 550034		



**Premium**  
 240 ÷ 320 Dxi 7  
 370-410-440-450 Dxi 11  
 Cabina corta e lunga / *Short and long cabin*





Data / Date		Dettagli veicolo / Vehicle's detail	
Da / Since :	11/2006	Motore : VOLVO 6 cil.	
Fino a / Until:		Engine : VOLVO 6 cil.	
Tipo assale / Axle type		Larghezza balestra / Leaf spring width	
<b>I</b>		90	

Corredato di  
*Equipped with*





Top Drive System Ref. :  **583966A**  
**583966E**  
**583966ET** 

<b>A</b>	Gonfiaggio <i>Inflating</i>	Anteriore Front
<b>E</b>	Autolivellante <i>Self-levelling</i>	
<b>T</b>	Elettrico <i>Electric</i>	Torpress T272/N Ø11"
	Elettrico con Telecomando <i>Remote controlled</i>	
550011 - 550021		

**Premium**  
**Versione rinforzata / Reinforced version**  
 240 ÷ 320 Dxi 7  
 370 ÷ 450 Dxi 11  
 Cabina corta e lunga / *Short and long cabin*



Data / Date		Dettagli veicolo / Vehicle's detail	
Da / Since :	11/2006	Motore : VOLVO 6 cil.	
Fino a / Until:		Engine : VOLVO 6 cil.	
Tipo assale / Axle type		Larghezza balestra / Leaf spring width	
<b>I</b>		90	

Corredato di  
*Equipped with*





Top Drive System Ref. :  **43116104**  
**43116107** 

<b>E</b>	Gonfiaggio <i>Inflating</i>	Anteriore Front
<b>T</b>	Elettrico <i>Electric</i>	
	Elettrico con Telecomando <i>Remote controlled</i>	Torpress 20 Ø10"
550044 - 550034		

**Magnum**  
 440 ÷ 520 Dxi 13



Data / Date		Dettagli veicolo / Vehicle's detail	
Da / Since :			
Fino a / Until:			
Tipo assale / Axle type		Larghezza balestra / Leaf spring width	
<b>I</b>		90	

Corredato di  
*Equipped with*





## Sospensioni Integrative per veicoli industriali Integrative Suspensions for industrial vehicles



Top Drive System Ref. :

	Gonfiaggio <i>Inflating</i>
E	Elettrico <i>Electric</i>
T	Elettrico con Telecomando <i>Remote controlled</i>

43116194

43116197

**Magnum**

**Versione rinforzata / Reinforced version**

440 ÷ 520 Dxi 13

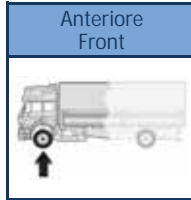

Data / Date		Dettagli veicolo / Vehicle's detail	
Da / Since :			
Fino a / Until:			
Tipo assale / Axle type		Larghezza balestra / Leaf spring width	
<b>I</b>			90



Corredato di  
*Equipped with*

**TOP DRIVE  
CONTROL**



WWW.TOPDRIVESYSTEM.COM

www.pneumauto.by