



Sospensioni Integrative per veicoli industriali Integrative Suspensions for industrial vehicles





Top Drive System Ref. :  **583056**
1117

A	Gonfiaggio <i>Inflating</i>	Posteriore Rear
	Autolivellante <i>Self-levelling</i>	
		Torpress 20 Ø10"
		
		550044 - 550034

E veicoli derivati - Fino ad esaurimento scorte / *Also for similar vehicles - Until stocks last*



Data / Date		Dettagli veicolo / Vehicle's detail	
Da / Since :			
Fino a / Until:			
Tipo assale / Axle type		Larghezza balestra / Leaf spring width	
	Quadro / Square BxH=140x150		

Corredato di
Equipped with





Top Drive System Ref. :  **583060A**
583060E
583060ET 

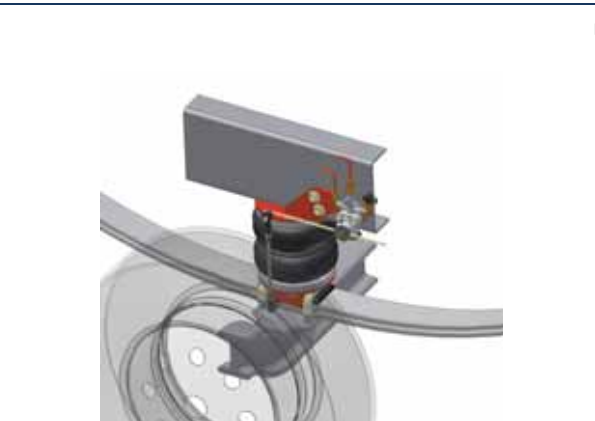

A	Gonfiaggio <i>Inflating</i>	Anteriore Front
	Autolivellante <i>Self-levelling</i>	
E	Elettrico <i>Electric</i>	
T	Elettrico con Telecomando <i>Remote controlled</i>	
		Torpress 20 Ø10"
		
		550044 - 550034



Atego
715 815 915
Sostituisce / Replace : 583058





Data / Date		Dettagli veicolo / Vehicle's detail	
Da / Since :	2001		
Fino a / Until:			
Tipo assale / Axle type		Larghezza balestra / Leaf spring width	
I			80

Corredato di
Equipped with



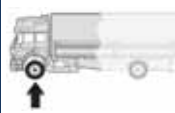

Top Drive System Ref. :  **583069A**
583069E
583069ET 

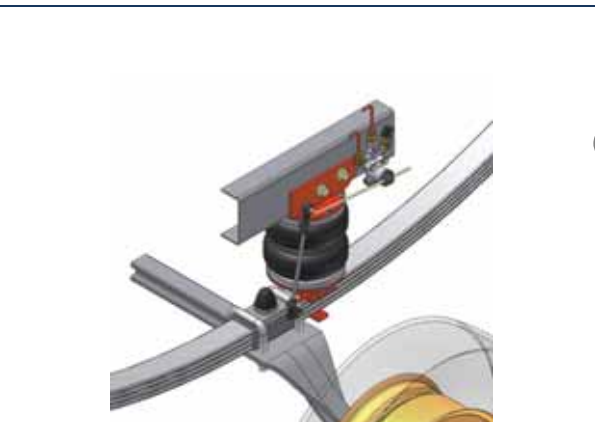

A	Gonfiaggio <i>Inflating</i>	Anteriore Front
	Autolivellante <i>Self-levelling</i>	
E	Elettrico <i>Electric</i>	
T	Elettrico con Telecomando <i>Remote controlled</i>	
		Torpress 20 Ø10"
		
		550044 - 550034

Atego
10.23 12.23 12.28



Data / Date		Dettagli veicolo / Vehicle's detail	
Da / Since :	03/2006		
Fino a / Until:			
Tipo assale / Axle type		Larghezza balestra / Leaf spring width	
I			80

Corredato di
Equipped with







Sospensioni Integrative per veicoli industriali Integrative Suspensions for industrial vehicles

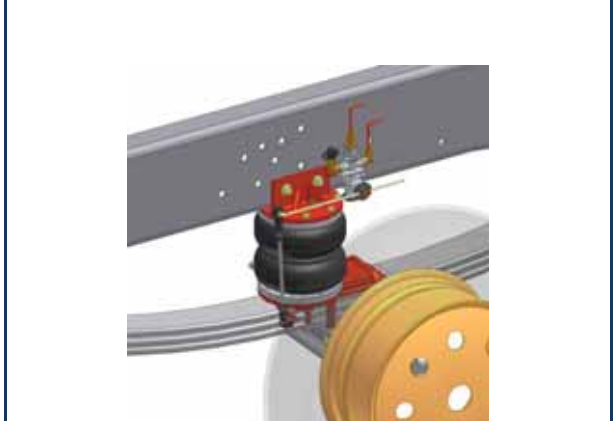

Top Drive System Ref. :		Gonfiaggio <i>Inflating</i>	Anteriore Front
583597A	A	Autolivellante <i>Self-levelling</i>	
583597E	E	Elettrico <i>Electric</i>	
583597ET	T	Elettrico con Telecomando <i>Remote controlled</i>	
Actros / Axor			Torpress 20 Ø10"
1832-1836-1841-1846-1848 V6			
2532-2536-2541-2544-2546-2548 V6			550044 - 550034
1851-1855-1860-2551-2555-2560 V8			



Data / Date		Dettagli veicolo / Vehicle's detail	
Da / Since :		Motore : MP2	
Fino a / Until:		Engine : MP2	
Tipo assale / Axle type		Larghezza balestra / Leaf spring width	
I		90	



Top Drive System Ref. :		Gonfiaggio <i>Inflating</i>	Anteriore Front
583997A	A	Autolivellante <i>Self-levelling</i>	
583997E	E	Elettrico <i>Electric</i>	
583997ET	T	Elettrico con Telecomando <i>Remote controlled</i>	
Actros / Axor			Torpress T272/N Ø11"
Versione rinforzata / Reinforced version			
1832-1836-1841-1846-1848 V6			550011 - 550021
2532-2536-2541-2544-2546-2548 V6			
1851-1855-1860-2551-2555-2560 V8			



Data / Date		Dettagli veicolo / Vehicle's detail	
Da / Since :		Motore : MP2	
Fino a / Until:		Engine : MP2	
Tipo assale / Axle type		Larghezza balestra / Leaf spring width	
I		90	



Top Drive System Ref. :		Gonfiaggio <i>Inflating</i>	Anteriore Front
42400293	A	Autolivellante <i>Self-levelling</i>	
42400294	E	Elettrico <i>Electric</i>	
42400297	T	Elettrico con Telecomando <i>Remote controlled</i>	
Actros / Axor			Torpress T272/N Ø11"
Versione rinforzata / Reinforced version			
Motore / Engine : MP3 - MP4			550011 - 550021



Data / Date		Dettagli veicolo / Vehicle's detail	
Da / Since :		Tampone fine corsa sulla balestra <i>Rebound pad on leaf spring</i>	
Fino a / Until:			
Tipo assale / Axle type		Larghezza balestra / Leaf spring width	
I		90	

